

Product Overview



Contents



Modular Plants

- 06 Jaw Modules
- 07 Cone Modules
- 08 Horizontal Screen Modules
- 09 Surge Bins



Portable Plants

- 11 Jaw Plants
- 12 Closed Circuit Cone / Screen Plants
- 13 Open Circuit Cone Plants
- 14 Horizontal Shaft Impactor Plants
- 15 Screen Plants
- 16 Wash Plants
- 17 Rip Rap



Static

- 22 Jaw Crusher
- 23 Roller Bearing Cone
- 24 Spider Bearing Cone Crusher
- 25 Horizontal Shaft Impactors
- 26 Horizontal Screens
- 27 Vibrating Grizzly Feeders



Parts

- 28 Parts

Cedarapids®

Power. Precision. Performance.

That's what A world working better™ means.

Cedarapids was founded in 1923 with the idea to revolutionize the road-building industry with the first truly portable aggregate plant. Over the last 100 years the company's portfolio has grown and revolutionized the Crushing & Screening Industry while remaining true to it's roots as a leader in portable plant equipment to customers around the world operating in four key industries:

- mining
- aggregates
- demolition and recycling
- industrial minerals

Our equipment is designed to produce the highest quality end products in processing hard and soft rock, sand and gravel, ore and industrial minerals.

We provide Modular and Portable plants and Static components – plus full parts, service and maintenance with support you can count on, wherever you are.

We understand your business

We know that you need operational reliability, cost-effectiveness and outstanding service. We've spent nearly one hundred years building our business around delivering all three. Because when you succeed, we succeed.

World Class Service and Support

With Cedarapids®, you don't just get best-in-class engineering technology. You get the service, training and support to match.

We understand your need to maximize productivity and control operating costs across the working life of every piece of equipment.

We share those goals – and have the solutions to help keep your operations running smoothly, through a dedicated global support network backed by decades of proven experience and expertise.



Cedarapids® Modular Plants

Flexible, Robust Design with Logistics in Mind.

Comprehensive, flexible and effective, the Cedarapids® Modular product range has been specifically created to meet a wide range of static crushing and screening applications.

All modules are pre-engineered and pre-built to operate on a small footprint with low civil engineering and operating costs with fast, easy on-site assembly and minimal wiring. Plus, the modules and components can be easily transported in standard shipping containers or by road, enabling you to quickly mobilize on site to a different location.

This means you can count on engineering technology that delivers in terms of maintenance access, longevity, and cost per ton. And of course, all backed by an expert global support network committed to keeping you operational, productive – and profitable.



Jaw Modules

The Cedarapids Range of modular jaw crushers simply crushes the competition. Designed with the end user in mind these plants have easy maintenance access and feature our world renowned jaw chambers for reliability and performance.

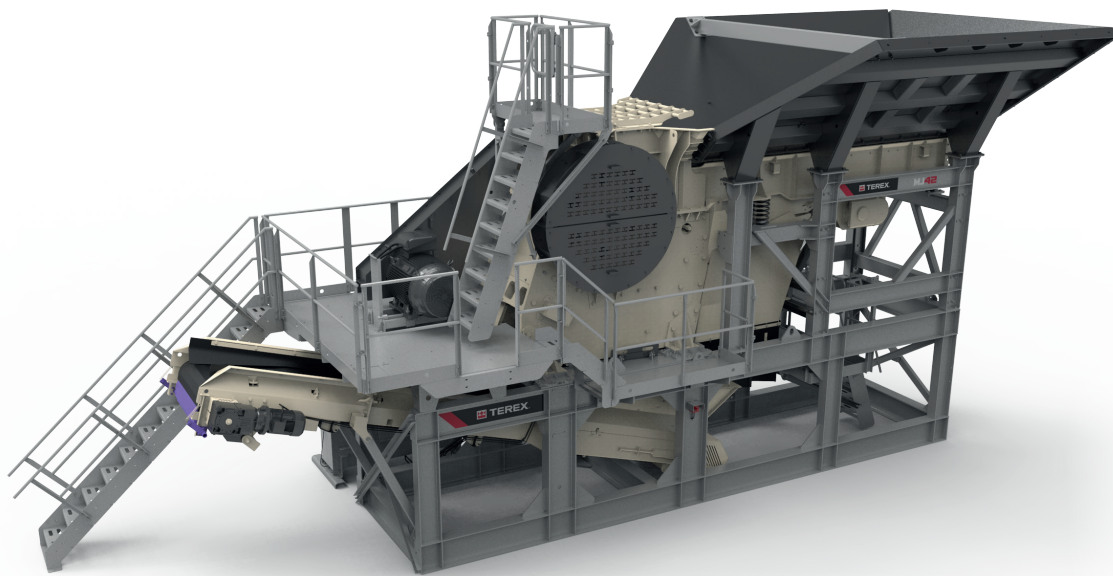

Model	Main Components	Motor Size	Capacity (MTPH)	Shipping Configuration
MJ42	JW42 (30" x 42") Jaw Crusher, 40" x 14' Feeder	150 hp (110 kW)	155-480 (140-435)	(3) 40ft shipping containers
MJ400R	TJ2844 (28" x 44") Jaw Crusher 40" x 14' Feeder	150 hp (110 kW)	127-281 (115 -255)	(3) 40ft shipping containers
MJ47	ST47 (36" x 48") Jaw Crusher, 51" x 24' Feeder	200 hp (150 kW)	210-670 (190-608)	(6) 40ft shipping containers plus (1) flat rack
MJ55	JW55 (32" x 55") Jaw Crusher, 52" x 20' Feeder	200 hp (150 kW)	255 - 760 (231 - 690)	(6) 40ft shipping containers plus (1) flat rack

Cone Modules

Cedarapids modular range of cone crushing equipment is unmatched in productivity and efficiency. Based on our Uni™ modular platform your Cedarapids modular cone crusher can grow with your business by only upgrading the cone crusher chamber and keeping your modular frame.



Model	Main Components	Motor Size	Capacity (MTPH)	Shipping Configuration
MC1000	TC1000 Cone Crusher	250 hp (185 kW)	75 -240 (68 - 218)	(1) 40ft shipping container plus (1) 20ft container
MC1150	TC1150 Cone Crusher	300 hp (224 kW)	165-320 (150 - 290)	(1) 40ft shipping container plus (1) 20ft container
MC1350	TC1300X Cone Crusher	400 hp (300kW)	325-375 (295-340)	MC1150 for shipping configurations
MC320	TG320 Cone Crusher	300hp (225 kW)	419-452 (380-410)	(1) 40ft shipping container plus (1) 20ft container
MC380X	MVP380X Cone Crusher	300 hp (224 kW)	170-560 (155-507)	(1) 40ft shipping container plus (1) 20ft container
MC450X	MVP450X Cone Crusher	400 hp (300 kW)	200-645 (182-585)	(1) 40ft shipping container plus (1) flat rack

Horizontal Screen Modules

Our modular screening range features the revolutionary Cedarapids horizontal screens, combining the efficient, high g-force legendary oval stroke action, and a large blending chute for a range of discharge options.



Model	Main Components	Motor Size	Shipping Configuration
MHS6203	TSV6203 (6' x 20') Three deck Horizontal screen	40 hp (30 kW)	(2) 40ft shipping container plus (1) flat rack or (1) additional shipping container
MHS8203	TSV8203 (8' x 20') Three deck Horizontal screen	50 hp (37 kW)	(2) 40ft shipping container plus (1) flat rack

Surge Bin Modules

Our Surge Bin Modules are designed to increase productivity by providing a constant flow of material to your modular plants.



Model	Main Components	Motor Size	Capacity (MT)	Shipping Configuration
MSF24	36" x 72" Vibrating Pan Feeder	2.5 hp (1.8 kW)	57 Ton (51)	(1) 20ft container

Cedarapids® Portable Plants

Exceptional Productivity and Efficiency.

Cedarapids® high-capacity portable crushing systems are designed to deliver and built to last. They're quick to set up, easy to operate and are low maintainance.

Their exceptional portability, productivity, efficiency and quality deliver real advantages over other systems.

Cedarapids® Portable Crushing & Screening Plants offer the essential flexibility, control and reliability to make the difference - whatever the application, wherever the location.

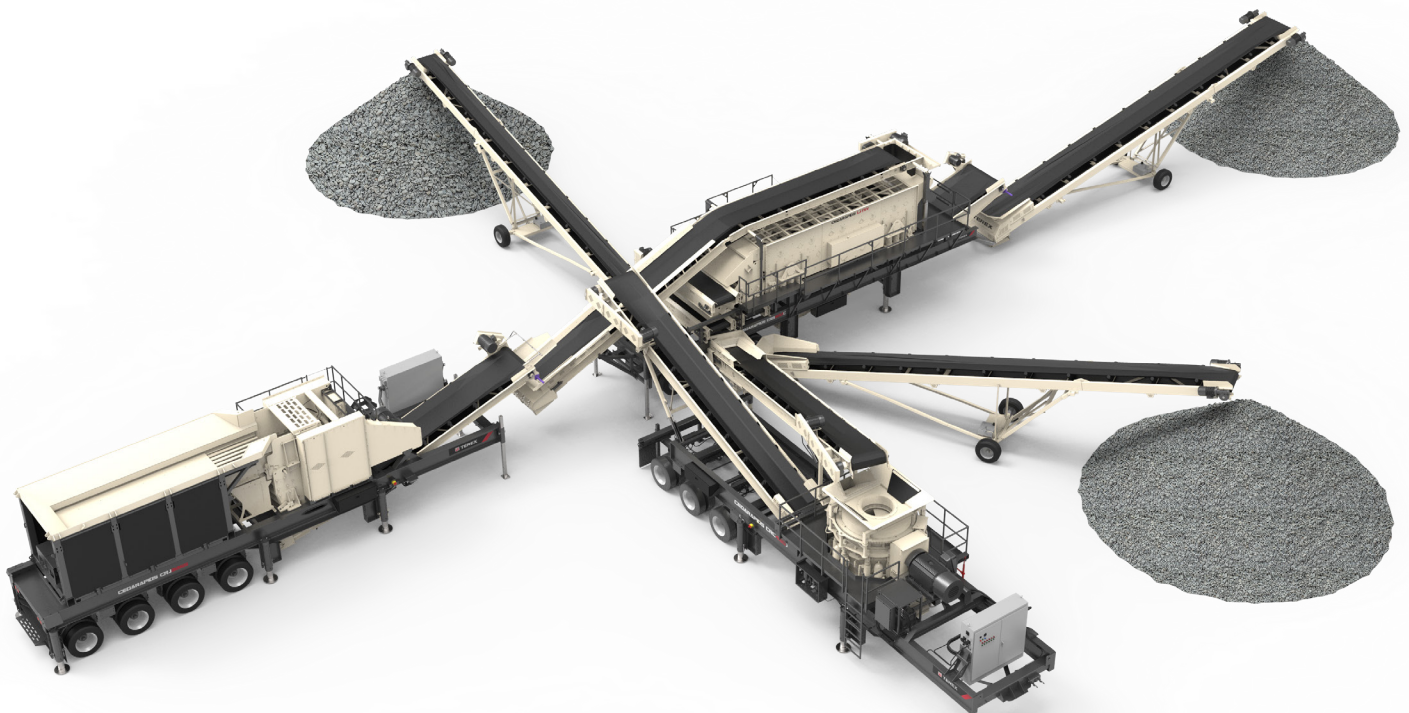

Jaw Plants

Combine the rugged reliability of our jaw crushers with a high production portable primary crushing machine and you've got Cedarapids® jaw plants.

These plants are the lead machine in many different crushing set-ups, and are ready to handle practically any material. Whether you're processing shot rock, sand and gravel, or recycling concrete, Cedarapids® jaw plants are guaranteed to perform – day in and day out.

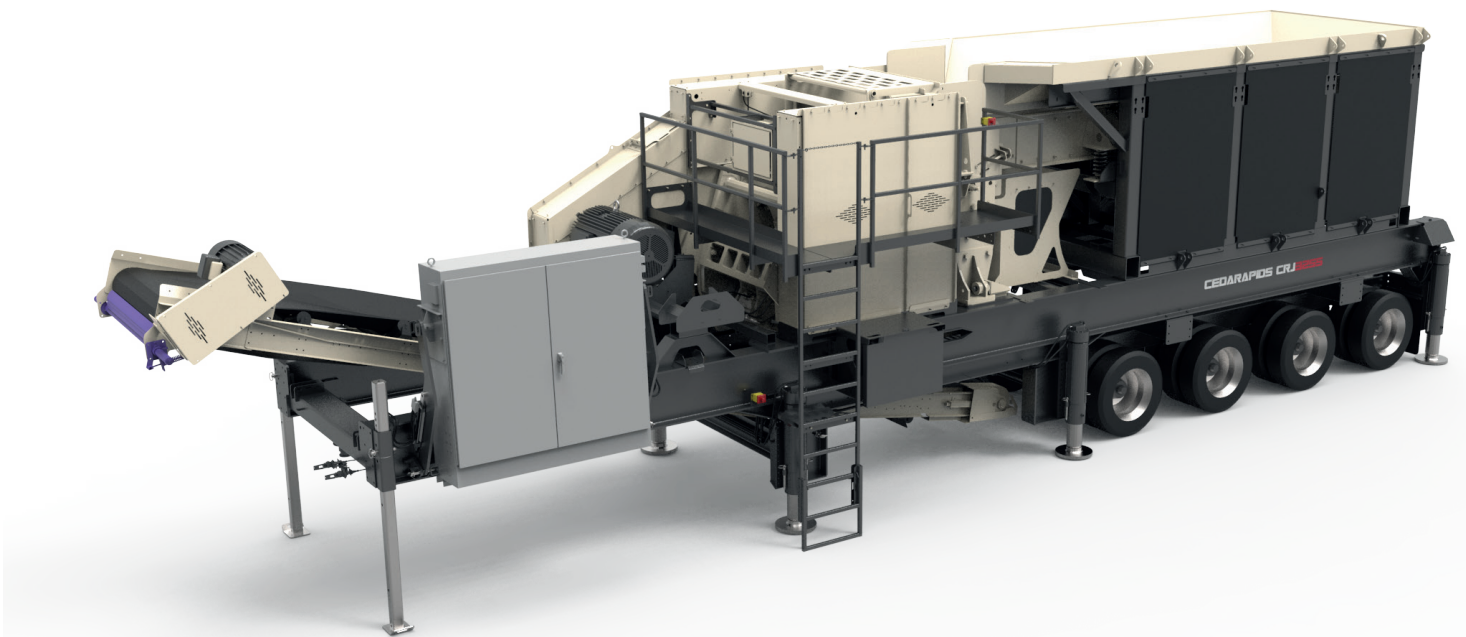

Model	Main Components	Motor Size	Capacity (MTPH)	Suspension	Weight lbs (Kg)
CRJ3042	JW42 (30" x 42") Jaw Crusher, 42" x 20' Feeder	150 hp (110 kW)	155 – 480 (140-435)	3 Axle	92,625 lbs (42,015 Kg)
CRJ3255	JW55 (32" x 55") Jaw Crusher, 52" x 20' / 24' Feeder	200 hp (150 kW)	255 – 760 (231 - 690)	4 Axle	135,585 lbs (61,500 Kg)

Closed Circuit Cone / Screen Plants

Cedarapids® leads the world with the most advanced portable plants - which include our closed-circuit cone/screen plants to maximize efficiency.

All of our closed circuit cone plants are designed for high productivity and easy portability - enabling you to get the most out of your machinery, and your investment.

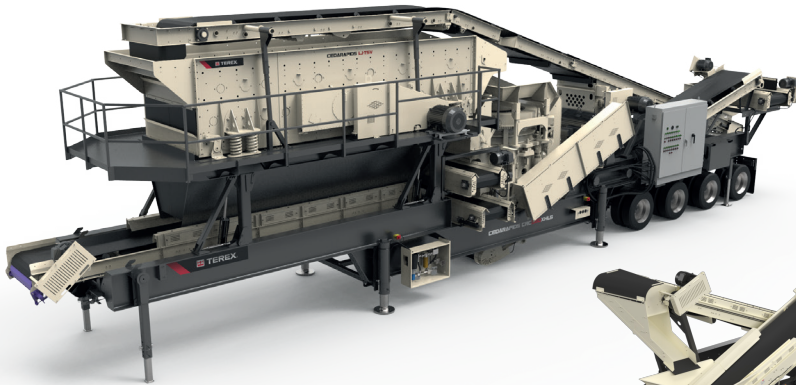

CRC380XHLS

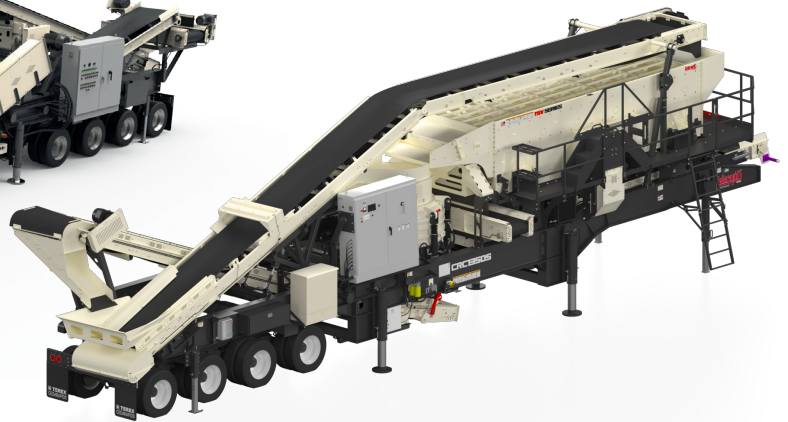

CRC1350S

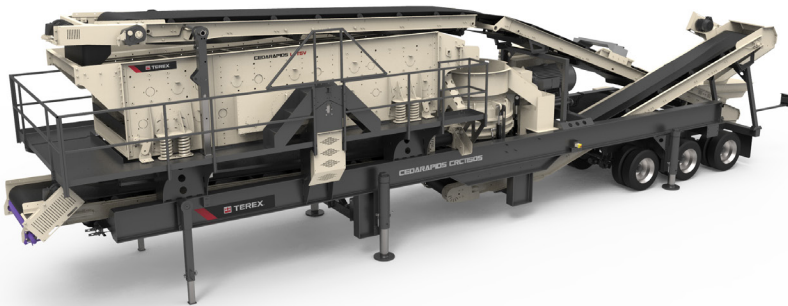

CRC1150S

Model	Main Components	Motor Size	Capacity (MTPH)	Suspension	Weight lbs (Kg)
CRC380XHLS	MVP380X cone and TSV6203 three deck screen	300 hp (224 kW)	170-560 (155-507)	4 Axle	138,300 lbs (62,735 Kg)
CRC1150S	TC1150 cone and TSV6203 three deck screen	300 hp (224 kW)	165-320 (150 - 290)	3 Axle	66,100 lbs (29,990 Kg)
CRC1350S	TC1300X cone crusher and TSV7203P horizontal three deck screen	400 hp (300 kW)	325-375 (295-340)	4 Axle	136,827 lbs (62,064 Kg)

Open Circuit Cone Plants

Cedarapids® open circuit cone plants are built for portability – and are ideal for applications involving hard, abrasive materials.

Most commonly set up in secondary, tertiary and quaternary crushing positions, they're available with numerous options and can be integrated with almost any portable crushing system.

Furthermore, since they are all-electric, our open circuit cone plants are easy to tie into new or existing systems.

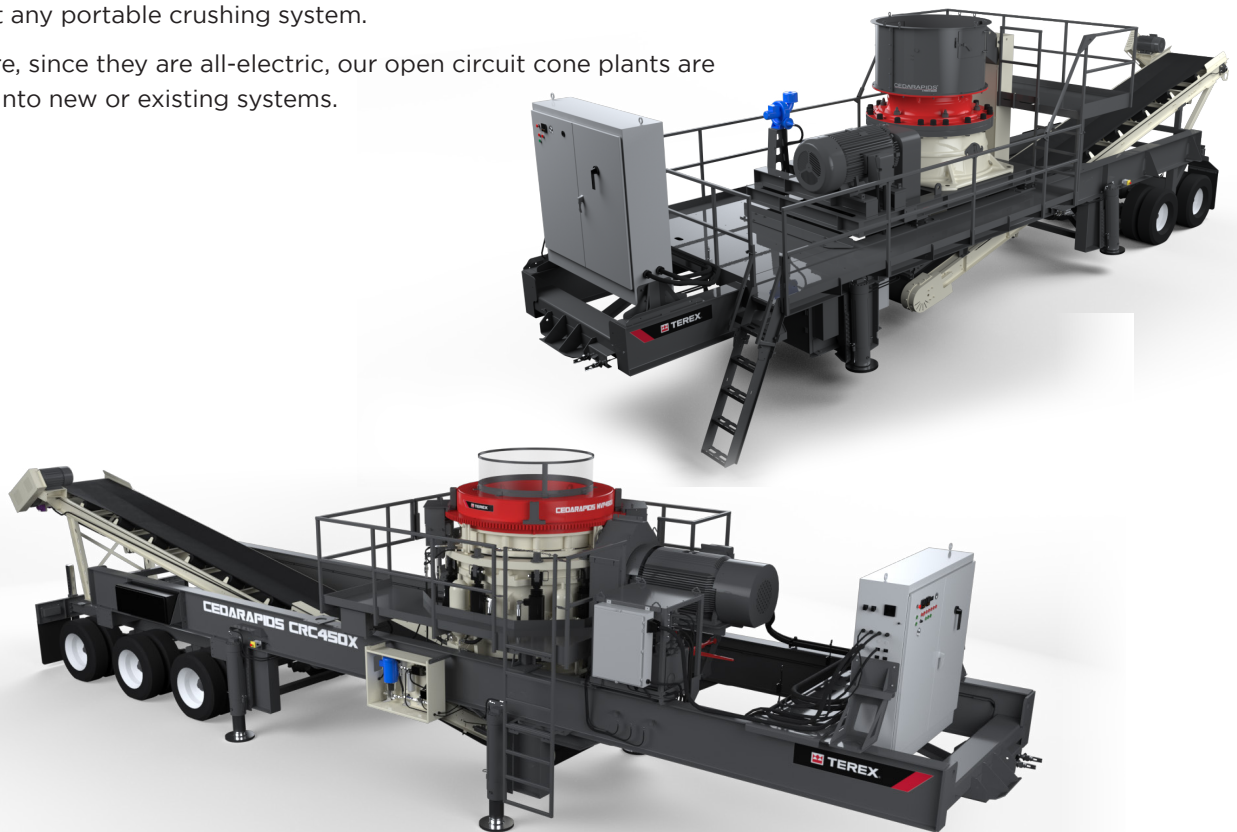

Model	Main Components	Motor Size	Capacity (MTPH)	Suspension	Weight lbs (Kg)
CRC1150	TC1150 cone	300 hp (224 kW)	165-320 (150 - 290)	2 Axle	66,100 lbs (29,990 Kg)
CRC320	TG320 cone	300hp (225 kW)	419-452 (380-410)	2 Axle	75,650 lbs (34,315 Kg)
CRC380X	MVP380X cone	300 hp (224 kW)	170-560 (155-507)	2 Axle	93,150 lbs (42,250 Kg)
CRC450X	MVP450X cone	400 hp (300 kW)	200-645 (182-585)	3 Axle	103,600 lbs (47,000 Kg)
CRC420	TG420 cone	400 hp (315 kW)	700-750 (640-680)	3 Axle	98,665 lbs (44,754Kg)
CRC1350	TC1300X cone	400 hp (300 kW)	325-375 (295-340)	3 Axle	82,944 lbs (37,623 Kg)

Horizontal Shaft Impactor Plants

These rugged horizontal shaft impact (HSI) crushers are matched with our high-stroke feeders to create portable crushing plants that are tough to beat in terms of productivity and efficiency – and designed to deliver years of tough crushing.

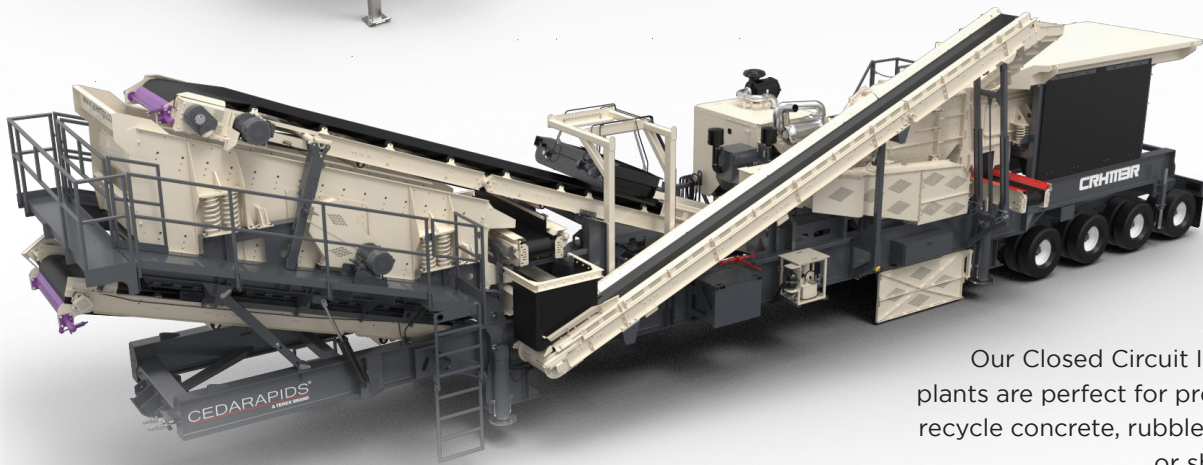

Our Closed Circuit Impactor plants are perfect for processing recycle concrete, rubble, asphalt or shot rock.

Model	Main Components	Crusher Size	Capacity (mtph)	Suspension	Weight lbs (Kg)
CRH1111R	41" x 43" Impact crusher, 43" x 14' VGF and 5' x 16' 2 Deck Inclined Screen (closed circuit plant)	200 hp (150 kW)	Up to 300 (270)	3 axle	103,650 lbs (47,015 Kg)
CRH1113R	42" x 50" Impact crusher, 48" x 18' VGF and 6' x 16' 2 Deck Inclined Screen (closed circuit plant)	300 hp (225 kW)	Up to 400 (360)	4 axle	128,070 lbs (58,092 Kg)
CRH1316	50" x 64" Impact crusher with 52" x 20' Feeder	400 hp (300 kW)	Up to 500 (455)	3 or 4 axle	121,050 lbs (54,910 Kg)

Screen Plants

Renowned for their performance and longevity, our Cedarapids® portable screen plants feature triple shaft horizontal screens with the legendary oval stroke design.

They are able to handle many variations of feed materials and can produce multiple products needed at specific locations. The plants are designed for scalping and finish screening applications and, with their numerous blending capabilities, can produce a wide range of product specifications.



Model	Main Components	Motor Size	Suspension	Weight lbs (Kg)
CRS620H	TSV6203 (6' x 20') Three Deck Horizontal Screen	40 hp (30 kW)	2 Axle	53,000 lbs (24,045 Kg)
CRS620S	TSV6203 (6' x 20') Three Deck Adjustable Slope Screen	40 hp (30 kW)	2 Axle	53,000 lbs (24,045 Kg)
CRS820H	TSV8203 (8' x 20') Three Deck Horizontal Screen	50 hp (31 kW)	2 Axle	61,000 lbs (27,770 Kg)
CRS820C	TSV8203 (8' x 20') Three Deck Horizontal Screen with Feed Conveyor	50 hp (31 kW)	3 Axle	84,700 lbs (38,419 Kg)

Wash Plant TXW Series

For portable screening with a complete spray system, look no further than the Cedarapids® range of portable wash plants. The screens are complemented by single or twin dewatering screws and fitted with strategically placed nozzles for material scrubbing. High capacity dewatering screws deliver the fine aggregates while chutes and cross conveyors deliver the sized products.

Screen Model	Screen Box Size	Screen
TXW516S	5' x 16'	single
TXW616T	6' x 16'	twin
TXW620HT	6' x 20'	twin

TXW Series Advantages

- Built using our proven Cedarapids® screen range of products for reliable production
- Available in Incline and Horizontal configurations to best support your operation
- Single and Twin screw plants available to meet production requirements.
- Designed with portability in mind, easy on/off landing jacks help reduce set up time
- Spray system can be adjusted to suit needs with spray bars located on all decks
- Chassis features heavy duty I-beam construction for improved stability

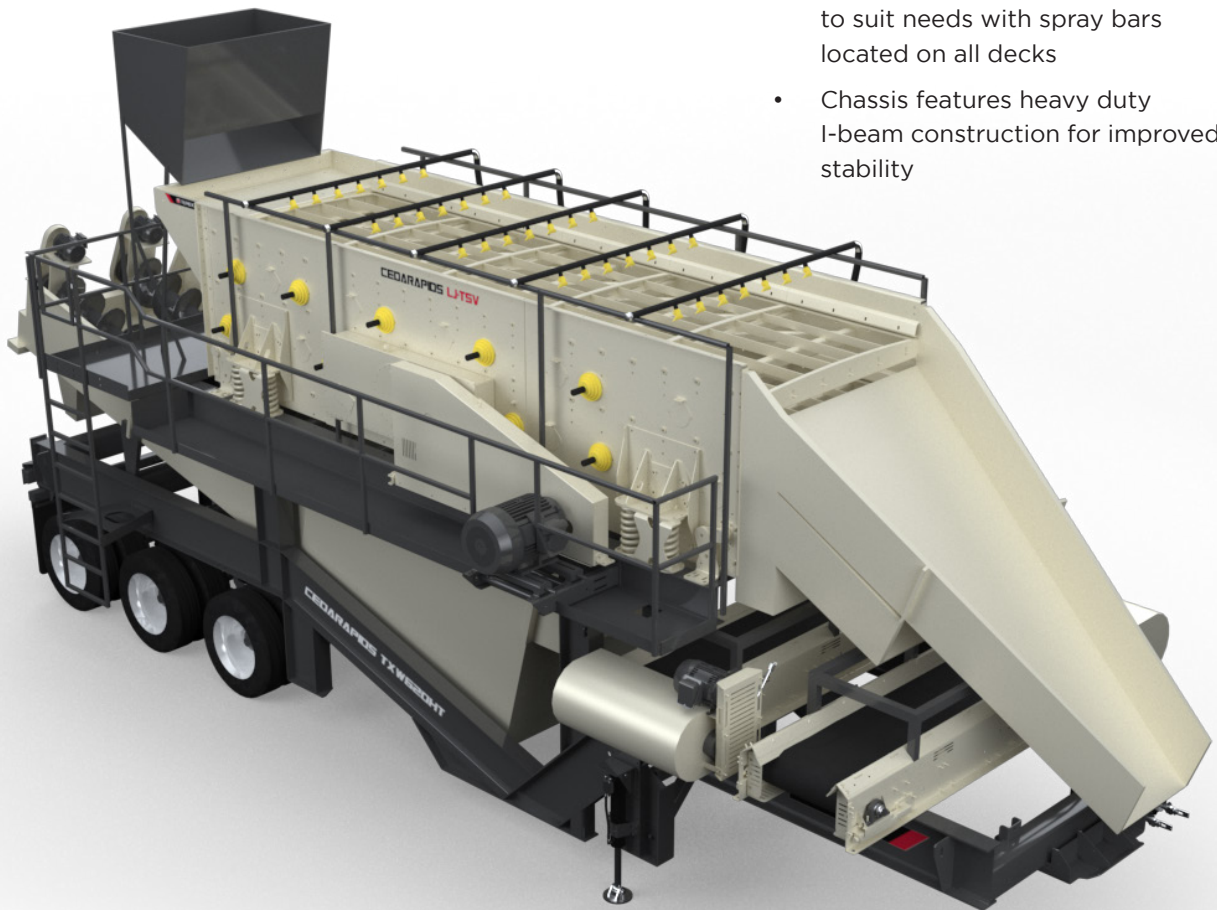

Rip Rap Plant

TXR5624

The Cedarapids® rip rap plant offers unsurpassed quality and construction in a self-contained portable design for the toughest high production screening and scalping applications. The TXR5624 rip rap plant sets the industry standard for even the most severe applications with a wide 56" wide by 24' long Simplicity vibrating grizzly feeder, optimized for severe duty operation. With two adjustable grizzly sections mounted in a step deck configuration, the unit can be configured to perform a wide variety of material separations. Heavy duty bars and liners ensure years of operation and minimal maintenance. Tall side walls in the hopper and guarded shrouds ensure maximum capacity for protection from damage. On-Plant Tier 4 generator allows for added starters to operate additional product conveyors for smooth operation and is available with an electric only option. Reversible cross conveyor and reversible heavy duty discharge chute are a standard configuration allowing you to set up the plant according to your particular layout.

TXR5624 Advantages

- Diesel or electric driven self-contained plant
- Heavy duty chassis and feeder
- High mobility with foldable 5th wheel hitch and three axle design
- Adjustable grizzly bars for variety of applications
- Tier 4 compliant
- Properly guarded for added protection





High Mobility Multi-Plant Solutions

Cedarapids modular and static plants are designed to work as one complete crushing system. Our Applications Team has years of valuable crushing and screening experience and can offer you expert guidance in choosing the right equipment to put together an efficient, cost effective system for your particular application.



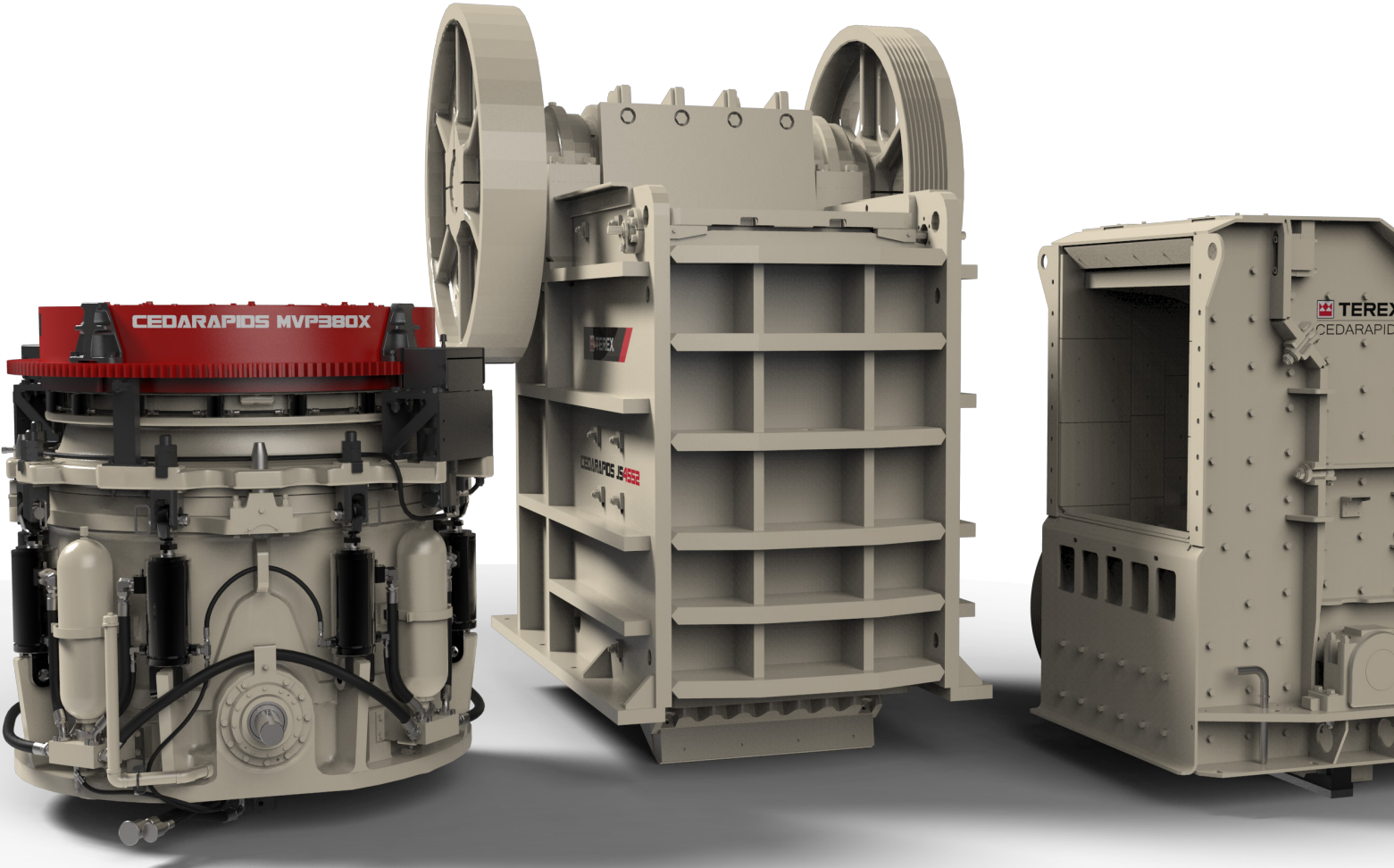

Cedarapids® Static

Designed
to Deliver.
Built to Last.

Cedarapids® Static products are designed with you in mind. That means we've built in ease of use. Flexibility. Reliability. Efficiency. This is equipment you can count on to deliver optimum performance, whatever your industry, whatever your location, day in and day out.

And with fast, easy maintenance as standard, you can look forward to minimal downtime and enhanced profitability.

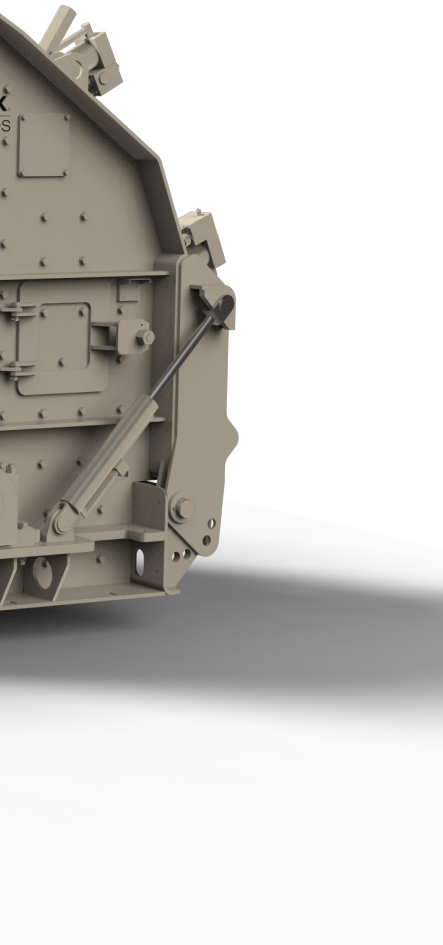

Jaw Crushers

Our jaw crushers with a proven track record of outstanding performance and productivity.

They're easy to use and built to last, designed to help you maximize profitability day in and day out.

With features like the advanced engineering behind the range is setting new standards for industry.



Model	Motor Size	Capacity (MTPH)	Feed Opening (mm)	Setting Range (mm)	Crusher Weight
JW42	150 hp (110 kW)	155 - 480 (140-435)	30 x 42" (762 x 1092)	3 - 8" (76 - 203)	39,100 lbs (17,700 Kg)
JW55	200 hp (150 kW)	255 - 760 (231 - 690)	32 x 55" (762 x 1391)	3.5 - 9" (85 - 225)	57,860 lbs (26,250 Kg)
JS4552	300 hp (225 kW)	200 - 1300 (180 - 1180)	45 x 52" (1143 x 1321)	4 - 12" (100 - 300)	104,600 lbs (47,450 Kg)
TJ2440	150hp (110kW)	220-320 (200-290)	24" x 40" (600x1000)	1.6" - 5.7" (40-146)	26,914 lbs (12, 208 kg)

Roller Bearing Cone Crushers

The advanced engineering behind our cone crushers is re-setting industry benchmarks. The cones feature the Rollercone® bearing design plus the hydro-pneumatic tramp iron relief system.

The full line-up, from 200 to 500 hp (150 to 375 kW), can process up to 800 tph (725 mtp) and is capable of handling sand and gravel, shot rock and recycled materials.

What's more, each model combines high product quality and high throughput capacities with low operational costs

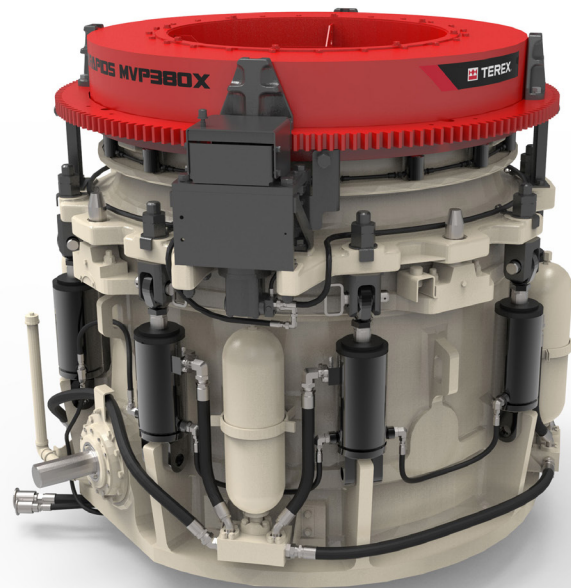

Model	Motor Size	Capacity (MTPH)	Maximum Feed Size	Cone Head Diameter	Crusher Weight
TC1000	250 hp (185 kW)	75 - 240 (68 - 218)	7 1/2" (195 mm)	40" (1016 mm)	22,040 lbs (9,997 Kg)
TC1150	300 hp (224 kW)	165-320 (150 - 290)	8 1/2" (220 mm)	45" (1143 mm)	31,360 lbs (14, 225 Kg)
TC1300X	400 hp (300 kW)	325-375 (295-340)	8.5" (220mm)	51" (1300mm)	39,917 lb (18,106kg)
MVP380X	300 hp (224 kW)	170-560 (155-507)	11 1/8" (283 mm)	48" (1219 mm)	46,000 lbs (20,800 Kg)
MVP450X	400 hp (300 kW)	200-645 (182-585)	12 15/16" (329 mm)	54" (1372 mm)	52,500 lbs (23,800 Kg)
MVP550X	500 hp (375 kW)	250-810 (228-737)	13 5/8" (346 mm)	60" (1524 mm)	68,000 lbs (30,800 Kg)

Spider Bearing Cone Crushers

These impressive new cone crushers can be easily & efficiently set up to perform and deliver the best cost per ton cubicle product by selecting the optimum crushing cavity and eccentric throw to suit the application requirements. From a course secondary right through to fine quaternary, the TG series cone crushers will consistently exceed all performance expectations.



Model	Motor Size	Capacity (MTPH)	Maximum Feed Size	CSS Range	Crusher Weight
TG120	120hp (90kW)	121-143 (110-130)	5" (125mm)	1/4 - 1 1/8" (6-29mm)	12,125lbs (5,500kg)
TG220	215hp (160kW)	215-237 (195-215)	6.5" (165mm)	1/4 - 1 1/4" (6-32mm)	20,945lbs (9,500kg)
TG320	335hp (250kW)	419-452 (380-410)	7.5" (190mm)	5/16 - 1 1/2" (8-38mm)	33,070lbs (15,000kg)
TG420	422hp (315kW)	706-750 (640-680)	9.5" (240mm)	1/2 - 1 3/4" (13-44mm)	55,556lbs (25,200kg)
TG820	805hp (600kW)	1543-1709 (1400-1550)	12.6" (320mm)	1/2 - 2 1/2" (13-64mm)	110,231lbs (50,000kg)
TG1020	1006hp (750kW)	2315-2535 (2100-2300)	13.2" (355mm)	1/2 - 2 3/4" (13-70mm)	170,000lbs (77,000kg)
TGS120	120hp (90kW)	146-158 (132-143)	7.5" (190mm)	5/16 - 1 1/8" (9-35mm)	15,102lbs (6,850kg)
TGS220	215hp (160kW)	358-379 (325-344)	10.8" (275mm)	3/4 - 1 3/8" (19-35mm)	26,676lbs (12,100kg)
TGS320	335hp (250kW)	634-662 (575-601)	13" (330mm)	1 1/8 - 1 7/8" (29-48mm)	42,990lbs (19,500kg)
TGS420	422hp (315kW)	1102-1157 (1000-1050)	15.2" (385mm)	1 1/2 - 2 3/4" (38-70mm)	80,469lbs (36,500kg)

*Maximum Feed Size based on a feed of F₉₅
Crusher range not to scale

Horizontal Shaft Impactors

With their large feed openings, heavy duty aprons and rugged rotors, our crushers are designed to handle big feed sizes and high capacity crushing.

The patented wedge bar system is just one of many features that ensure reliable operation. Maintenance is fast and easy, which helps minimize downtime.

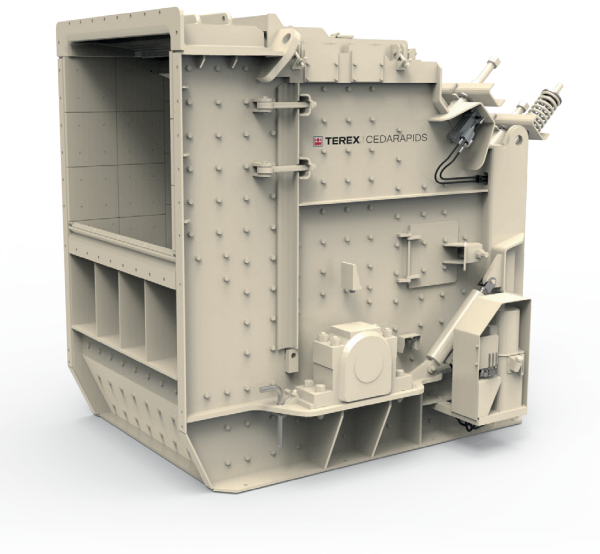
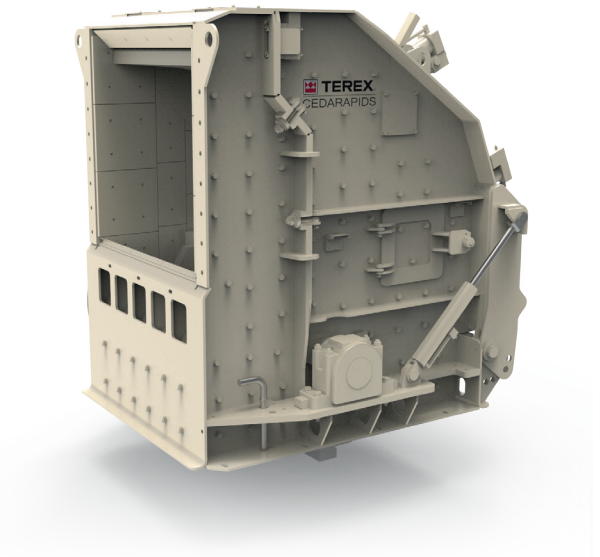

Model	Motor Size	Capacity (mtph)	Inlet Size (mm)	Rotor Size Diameter x Width (mm)	Number of Blowbars	Crusher Weight
TI4143	180 hp (130 kW)	90-300 (80 - 270)	31" x 44" (800 x 1130)	41" x 43" (1035 x 1100)	4	21,915 lbs (9,940 Kg)
TI4250	240hp (180kW)	150 - 529 (136- 480)	50" x 34" (1270 x 871)	42" x 50" (1065 x 1270)	4	27,397 lbs (12,453 kg)
IP1316	400 hp (300 kW)	250 - 400 (225-365)	43" x 64" (1100 x 1645)	50 x 64" (1270 x 1625)	3	38,500 lbs (17,465 Kg)
IP1516	600 hp (450 kW)	600-800 (545-725)	52" x 65" (1320 x 1650)	61 x 64" (1550 x 1625)	3	55,700 lbs (25,260 Kg)

Horizontal Screens

The TSV screen is built even stronger and combines the legendary oval stroke with the unique ability to install at various slopes, increasing production and handling more applications than traditional horizontal screens.

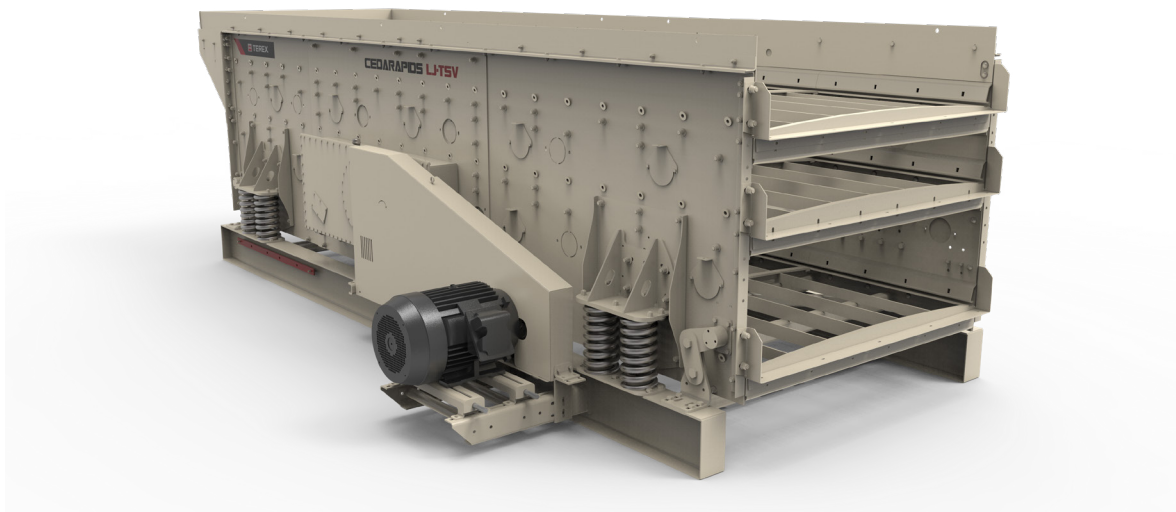

Screen	Motor Size	Weight	Bearing Size	Length (mm)	Width (mm)	Number of Decks
TSV 5162-26	25 hp (19 kW)	13100 (5,942 Kg)	130mm	192" (4877)	64" (1626)	2
TSV 5163-26	30 (22 kW)	16600 (7,530 Kg)	130mm	192" (4877)	64" (1626)	3
TSV 6162-32	30 (22 kW)	15900 (7,212 Kg)	160mm	192" (4877)	76" (1930)	2
TSV 6163-32	40 (30 kW)	19600 (8,890 Kg)	160mm	192" (4877)	76" (1930)	3
TSV 6202-32	40 (30 kW)	19100 (8,665 Kg)	160mm	240" (6096)	76" (1930)	2
TSV 6203-32	40 (30 kW)	22650 (10,275 Kg)	160mm	240" (6096)	76" (1930)	3
TSV 7202-38	50 (37 kW)	23000 (10,435 Kg)	190mm	240" (6096)	88" (2235)	2
TSV 7203-38	50 (37 kW)	27500 (12,475 Kg)	190mm	240" (6096)	88" (2235)	3
TSV 8202-38	50 (37 kW)	24250 (11,000 Kg)	190mm	240" (6096)	100" (2540)	2
TSV 8203-38	50 (37 kW)	29500 (13,385 Kg)	190mm	240" (6096)	100" (2540)	3

Vibrating Grizzly Feeders

The Advantage Series VGF provides high production and long service life in a wide range of rigorous applications. The feeder design allows for better crushing equipment utilization. The large stroke produces high throughput tonnage with superior material separation at the grizzly. You get the most out of your primary crusher by feeding only what needs to be crushed. Overall operating costs are decreased, strengthening your return on investment

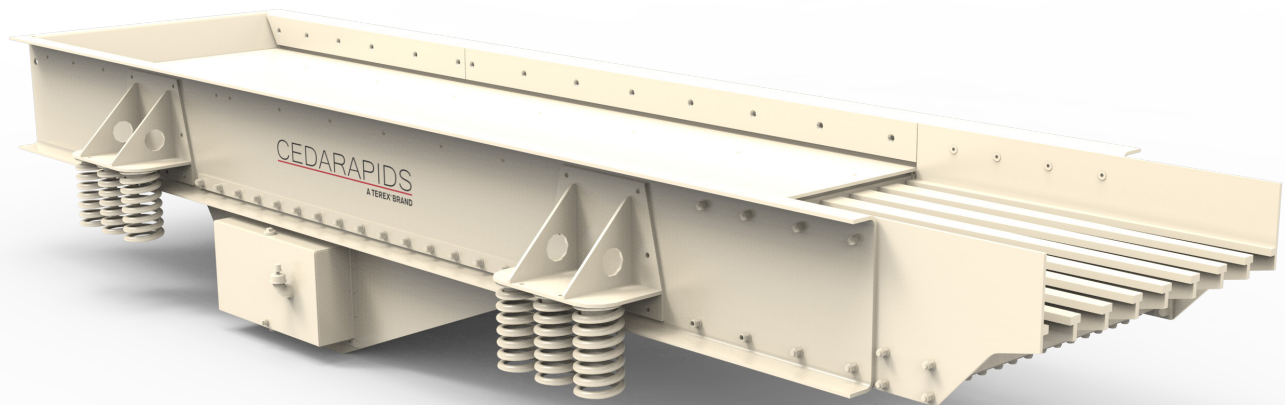

Model	Motor Size	Width (mm)	Length (mm)	Pan Length (mm)	Bearings	Weight
VGF3517-12	30 hp (22.5 kW)	35" (889)	17' (5182)	12' (3658)	90 mm	9000 lbs (4082 Kg)
VGF4217-12	40 hp (30 kW)	42" (1067)	17' (5182)	12' (3658)	100 mm	10,000 lbs (4536 Kg)
VGF4220-15	40 hp (30 kW)	42" (1067)	20' (6096)	15' (4572)	100 mm	11,200 lbs (5080 Kg)
VGF5220-15	40 hp (30 kW)	52" (1321)	20' (6096)	15' (4572)	100 mm	12,500 lbs (5670 Kg)
VGF5224-19	40 hp (30 kW)	52" (1321)	24' (7315)	19' (5791)	100 mm	14,000 lbs (6350 Kg)

Cedarapids® Services

Proven Success, Global Reach

A comprehensive range of services. Original spare and wear parts. Customizable solutions to meet your exact needs. Outstanding technical expertise and support.

This is what Cedarapids® delivers to businesses – and what it delivers to businesses throughout the world via our global distribution network, service and distribution facilities and regional warehouses.

Spare and Wear Part Support

Our OEM parts help maintain and enhance the performance of your equipment – and you can count on us to get you the spare and wear parts you need, when you need them.

Cedarapids® parts are manufactured according to exact specifications, using high-quality materials, tools and techniques. By using genuine parts you are helping to ensure the maximum performance and longevity of your machines.

A Shared Focus

We understand your key focus is delivering your operational and financial goals. We share that focus: it's how we both measure success.

By combining our global service network and proven, in-depth industry knowledge with your operational expertise we're able to provide you with the right solution to deliver a quality end product – with increased productivity.

Field Services

We offer a comprehensive set of field services to meet your maintenance, repair and refurbishment needs – which means you get a cost-effective alternative to purchasing new or replacement equipment.

Our experienced field service and distribution network are available to you on site or at our global service facilities. We can repair broken or damaged equipment to like-new condition and restore worn or irreplaceable equipment to perfect operating condition – which minimizes costly downtime for you.



Combining our global service network and deep industry knowledge with your operational expertise ensures that we provide the best solutions...

Terex® Financial Services

At Cedarapids® we not only offer a strong and broad product portfolio. We also offer the means for customers to purchase the equipment they need in order to meet their operational and profitability goals.

Terex® Financial Services is a globally trusted resource that is able to leverage its knowledge of Terex® equipment plus its marketplace expertise to provide a unique tailored solution for customers.

Terex® Financial Services at a Glance

- Providing cost-effective financial solutions to thousands of customers across the globe
- A comprehensive suite of financial solutions tailored to fit individual needs
- Dedicated and knowledgeable team with global reach, focused on customer solutions.

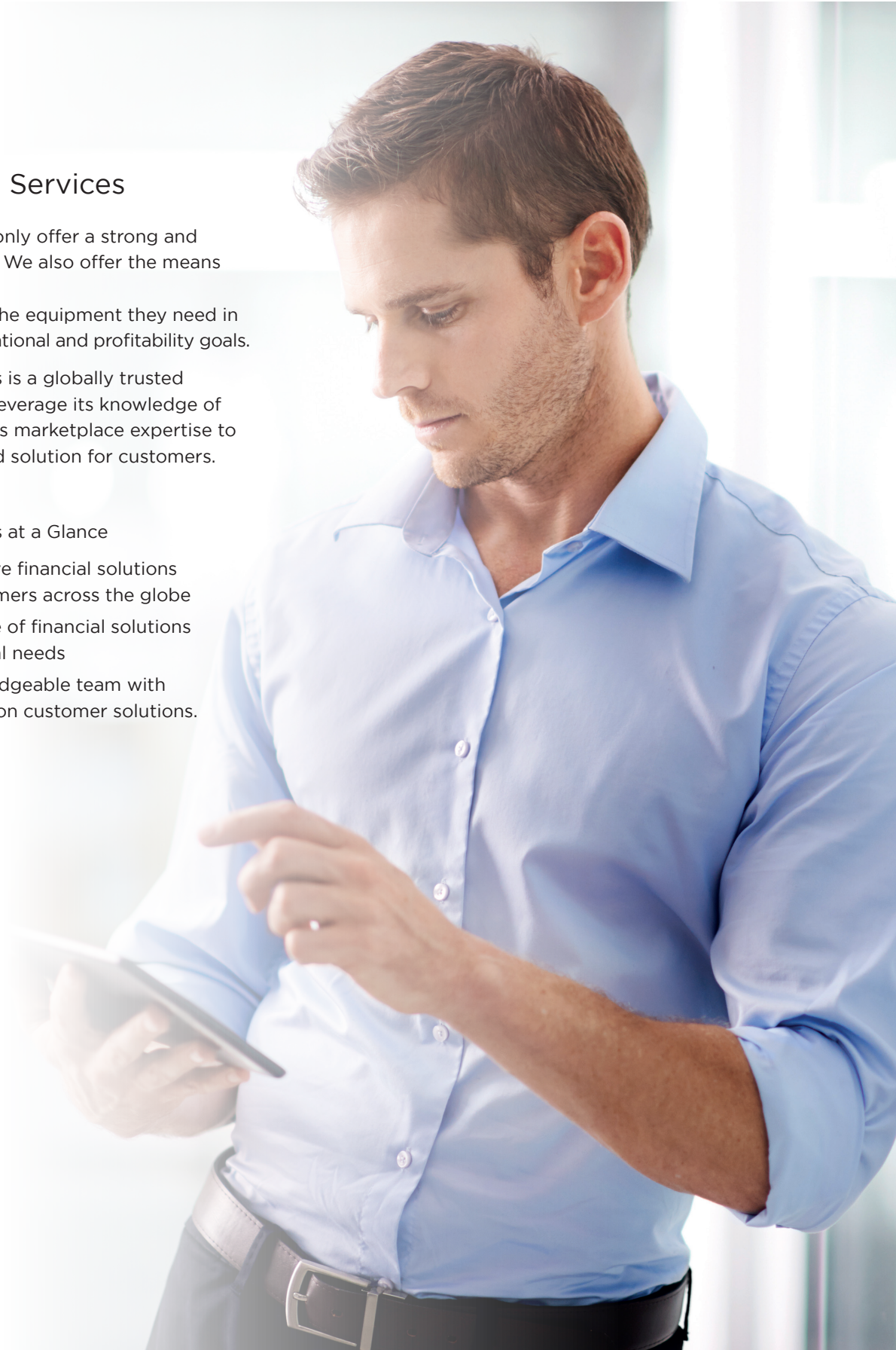



www.terexmps.com
mpsmarketing@terex.com

Product specifications and prices are subject to change without notice or obligation. The photographs and/or drawings in this document are for illustrative purposes only. Refer to the appropriate Operator's Manual for instructions on the proper use of this equipment.

Failure to follow the appropriate Operator's Manual when using our equipment or failure to act responsibly may result in serious injury or death.

The only warranty applicable to our equipment is the standard written warranty applicable to the particular product and sale, and Terex makes no other warranty, express or implied. Terex, the Terex Crown design, Cedarapids, Canica, Simplicity, Jaques, and Rollercone are trademarks of Terex Corporation or its subsidiaries. All rights are reserved. © Oct 2024

