

KOMATSU®

HD605-7R

HD
605

HORSEPOWER

Gross: 551 kW 739 HP/2000 min⁻¹

Net: 533 kW 715 HP/2000 min⁻¹

MAXIMUM PAYLOAD

63 metric tons

BODY CAPACITY (Heaped 2:1, SAE)

40.0 m³



Photos may include optional equipment.

WALK-AROUND





PERFORMANCE FEATURES

- High Performance Komatsu SAA6D170E-5 Engine
- Mode Selection System Automatic Idling Setting System
- Automatic Retard Speed Control (ARSC)
- K-ATOMiCS with "Skip-Shift" Function
- Small Turning Radius
- Automatic Spin Regulator (ASR) (Optional)
- Long Wheelbase and Wide Tread
- Payload Meter (PLM) (Optional)
- Fully Hydraulic Controlled Wet Multiple-Disc Brakes and Retarder
- Large Body

OPERATOR ENVIRONMENT

- Ergonomically Designed Cab Easy-to-See Instrument Panel
- Viscous Cab Mounts Built-in ROPS/FOPS Cab
- Supplementary Steering and Secondary Brake
- Hydropneumatic Suspension for All Terrains
- Three-Mode Automatic Hydropneumatic Suspension (Optional)
- Electronic Hoist Control System

RELIABILITY

- Komatsu Components High-Rigidity Frame
- Robust Dump Body Design Reliable Hydraulic System
- Protection Functions Supported by Electronic Control
- Sealed DT Connectors Lead-Free Radiator
- Flat Face-to-Face O-ring Seals Brake Cooling Oil Recovery Tank

EASY MAINTENANCE

- Advanced Monitoring System
- Wet Multiple-Disc Brakes and Fully Hydraulic Controlled Braking Systems
- Centralized Arrangement of Filters Disc Wheels (Flange Type Rims)
- Extended Oil Change Intervals Electric Circuit Breaker
- Centralized Greasing Points KOMTRAX Plus

HD605-7R

HORSEPOWER	Gross: 551 kW 739 HP/2000min ⁻¹
	Net: 533 kW 715 HP/2000min ⁻¹
MAXIMUM PAYLOAD	63.0 metric tons
BODY CAPACITY (Heaped 2:1, SAE)	40.0 m ³

PERFORMANCE FEATURES

Komatsu Technology

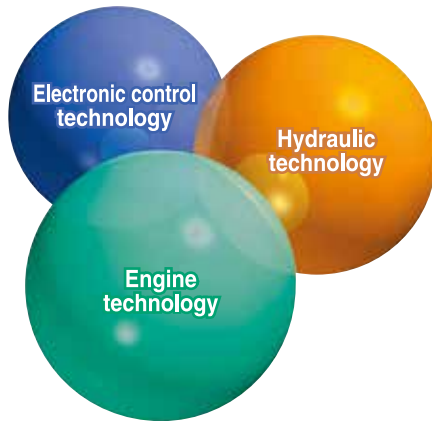

Komatsu develops and produces all major components, such as engines, electronics and hydraulic components, in house. With this "Komatsu Technology," and adding customer feedback, Komatsu is achieving great advancements in technology.

To achieve both high levels of productivity and economical performance, Komatsu has developed the main components with a total control system.

The result is a new generation of high performance and environment friendly machines.

High Performance Komatsu SAA6D170E-5 Engine

Powerful turbocharged and air-to-air aftercooled Komatsu SAA6D170E-5 engine provides **533 kW** 715 HP (Net). This engine realizes high power in low fuel consumption with Common Rail Injection system (CRI), and thus it delivers higher travel speeds with high horsepower. Also high torque at low speed, impressive acceleration, and low fuel consumption ensure maximum productivity.

Mode Selection System

The system allows selection of the appropriate mode between two modes <Power mode > or <Economy mode> according to each working condition. The mode is easily selected with a switch in the operator's cab.

Power mode

Great productivity can be attained by taking full advantage of high output power. It is appropriate for job sites where larger production uphill-hauling is required.

Economy mode (Variable horsepower control)

The engine power automatically changes depending on loaded or unloaded conditions always to use an optimum speed gear. It is appropriate for light work on flat ground.

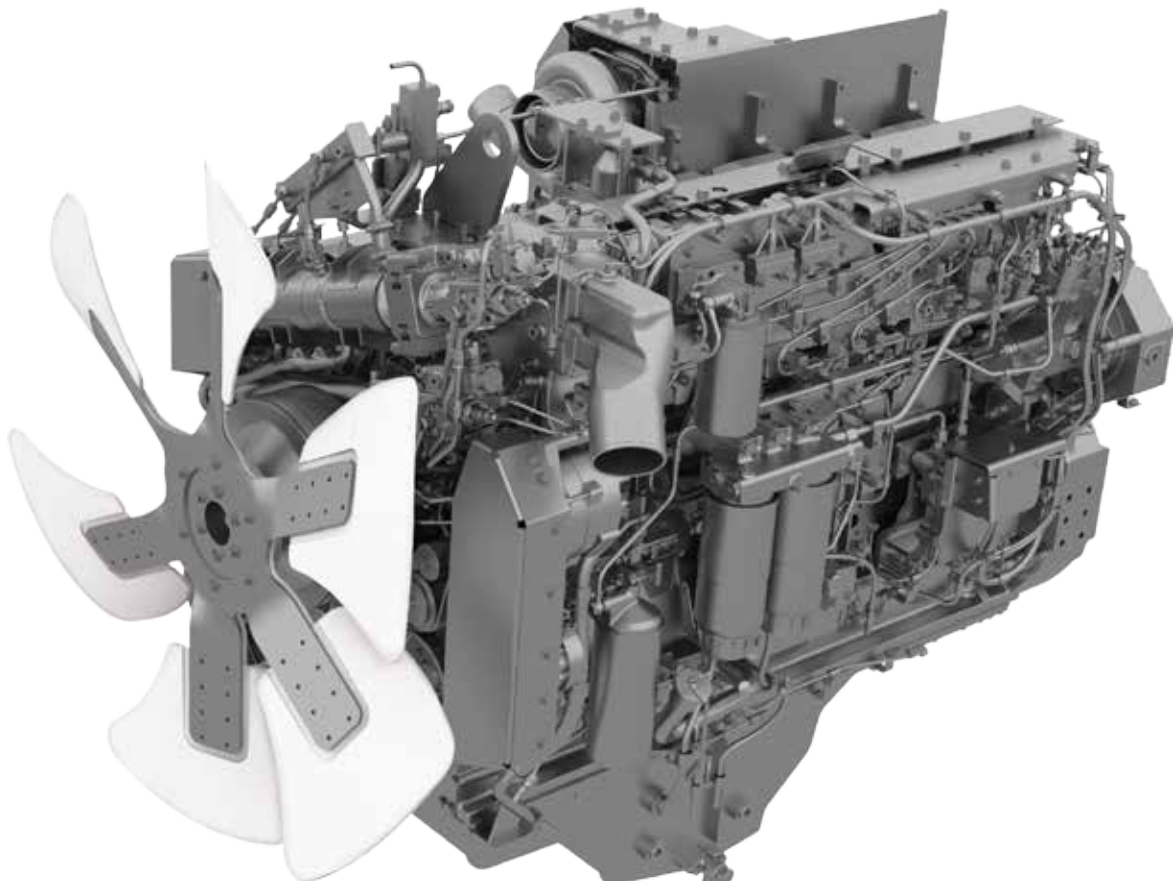

Automatic Idling Setting System

This system facilitates quick engine warm-up and cab cooling/warming. When setting the system ON, engine idle speed is kept at 945 min⁻¹ when coolant temperature is 50°C or lower. Speed automatically returns to 750 min⁻¹ when coolant temperature reaches 50°C.



7-Speed, Fully Automatic K-ATOMiCS Transmission

The K-ATOMiCS (Komatsu Advanced Transmission with Optimum Modulation Control System) automatically selects the optimum gear according to vehicle speed, engine speed and the shift position you've chosen. The result: the best gear for any driving situation.



Automatic Retard Speed Control (ARSC)

ARSC allows the operator to simply set the downhill travel speed and go down slopes at a constant speed. As a result, the operator can concentrate on steering. The speed can be set at increments of 1 km/h 0.6 MPH per click (±5 km/h 3.1 MPH of setting speed adjustment) to match the optimum speed for the slope. Also, since the retarder cooling oil temperature is always monitored, the speed is automatically lowered.



K-ATOMiCS with "Skip-Shift" Function

An electronically controlled valve is provided for each clutch pack in the transmission for independent clutch engagement/disengagement. It enables an ideal change in clutch modulation pressure and torque cut-off timing in response to travel conditions. This system and newly added "skip-shift" function ensure smooth shifting and responsive acceleration.

"Skip-shift" function

Optimum travel speed automatically selected in response to angle of ascent. Reduced frequency of downshift and smoother operation are provided.

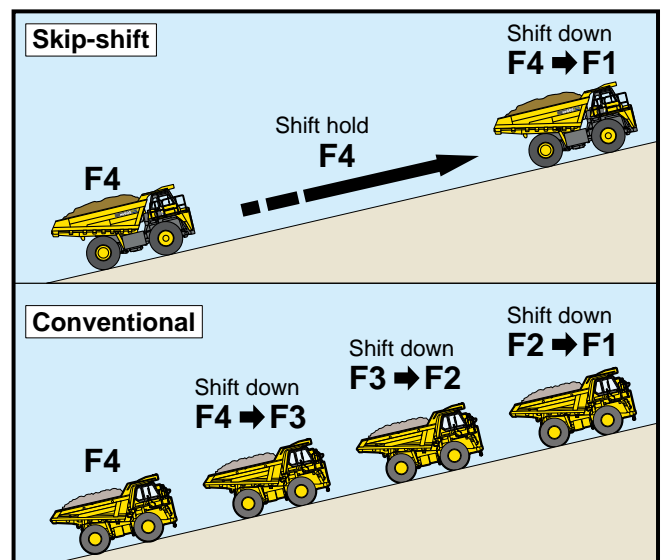

Small Turning Radius

The MacPherson strut type front suspension has a special A-frame between each wheel and the main frame. The wider spaces created between the front wheels and the main frame increase the steering angle of the wheels. The larger this steering angle, the smaller the turning radius of the truck.

Turning radius varies depending on ground conditions and/or vehicle speed.

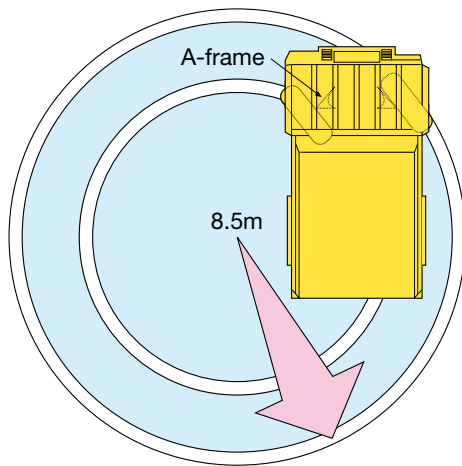

Automatic Spin Regulator (ASR) (Optional)

ASR automatically prevents the rear tires on either side from slipping on soft ground for optimal traction.

Long Wheelbase and Wide Tread

With an extra-long wheelbase, a wide tread and an exceptionally low center of gravity, the HD605-7R hauls the load at higher speed for greater productivity, and delivers superior driving comfort over rough terrain.

Payload Meter (PLM) (Optional)

PLM allows the production volume and the working conditions of the dump truck to be analyzed directly via a personal computer (PC). The PLM data can be downloaded directly from HD605-7R to your PC by connecting the cable. The loaded weight is indicated on the payload display (character display) and the external display lamp while loading.



Fully Hydraulic Controlled Wet Multiple-Disc Brakes and Retarder

Wet multiple-disc brakes ensures highly reliable and stable brake performance. The large-capacity, continuously cooled, wet multiple-disc brakes also function as a highly responsive retarder which gives the operator greater confidence at higher speeds when travelling downhill.

- Retarder Absorbing Capacity
(continuous descent): 785 kW 1,052 HP
- Brake Surface Area (rear): 64,230 cm²

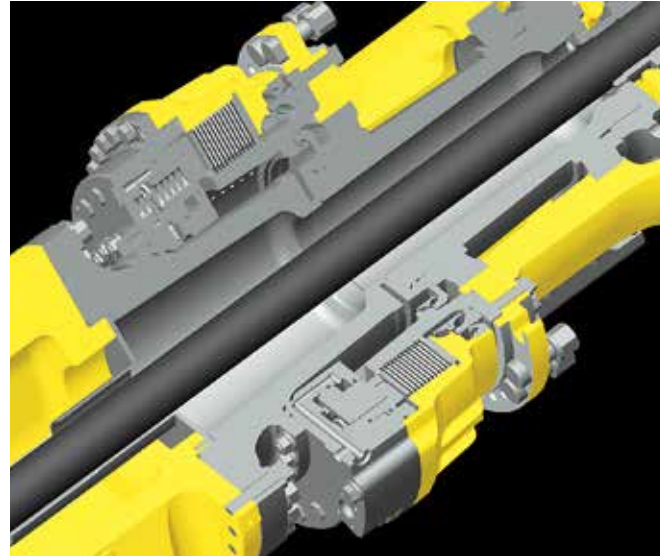

Large Body

A wide target area makes for easy loading with minimal soil spillage and more efficient hauling. The V-shape design also increases structural strength, and provides excellent load stability.



OPERATOR ENVIRONMENT

Ergonomically Designed Cab

The ergonomically designed operator's compartment makes it very easy and comfortable for the operator to use all the controls. The result is more confident operation and greater productivity.



Wide, Spacious Cab with Excellent Visibility

Wide windows in the front, side and back, plus plenty of space in the richly upholstered interior, provide quiet, comfortable environment from which to see and control every aspect of operation. Front under view mirrors and side under view mirrors have been added to improve safety.

Easy-to-See Instrument Panel

The instrument panel makes it easy to monitor critical machine functions. In addition, a caution light warns the operator of any problems that may occur. Problems are recorded in the monitor and indicated as service codes.

This makes the machine user friendly and easy to service.

Viscous Cab Mounts

Viscous mounts reduce the noise transmitted to the cab and achieve a quiet 77 dB(A) noise level.

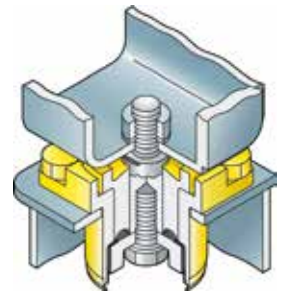

Ideal Driving Position Settings

The 5-way adjustable operator seat and the tilt-telescopic steering column provide an optimum driving posture, for increased driving comfort and more control over machine operation. The suspension seat dampens vibrations transmitted from the machine and reduces operator fatigue as well as holding the operator securely to assure confident operation. 78 mm width seat belt is provided as standard equipment.



Built-in ROPS/FOPS Cab

These structures conform to ISO 3471 ROPS standard, and ISO 3449 FOPS standard.



Supplementary Steering and Secondary Brake

Supplementary steering and secondary brakes are standard features.

Steering: ISO 5010, SAE J1511

Brakes: ISO 3450

If there should be a failure in the foot brake, the parking brake and front disc brakes are activated as a pedal operated secondary brake. In addition, when hydraulic pressure drops below the rated level, the parking brake is automatically actuated.



Secondary Brake

Antilock Brake System (ABS) (Optional)

Using its outstanding electronics technology, Komatsu is the first in the industry to introduce ABS on construction machinery. This system prevents the tires from locking, thus minimizes skidding under slippery conditions while applying the service brake.

Hydropneumatic Suspension for All Terrains

The hydropneumatic suspension assures a comfortable ride even over rough terrain and ensures maximum productivity and operator confidence.

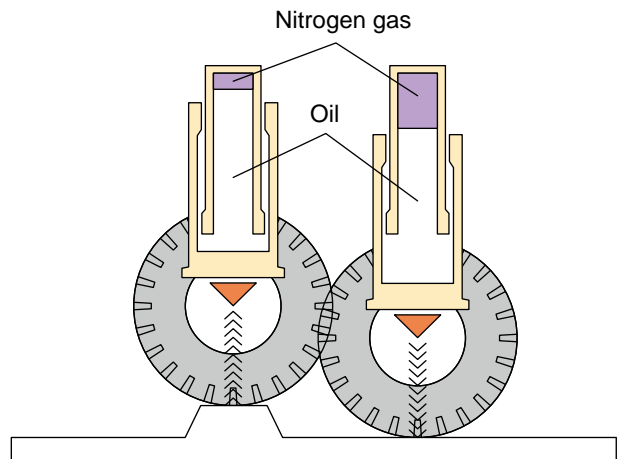

Three-Mode Automatic Hydropneumatic Suspension (Optional)

Suspension mode is automatically switched to one of three stages (Soft, medium and hard) according to load and operating conditions, for a more comfortable and stable ride.

Electronic Hoist Control System

The low effort lever makes dumping easy. A positioning sensor is installed for dump body control which significantly reduces the shock made by the lowering of the dump body.



RELIABILITY

Komatsu Components

Komatsu manufactures the engine, torque converter, transmission, hydraulic units, and electrical parts on this dump truck. Komatsu dump trucks are manufactured with an integrated production system under strict quality control system guidelines.

High-Rigidity Frame

Cast-steel components are used in the main frame for high stress areas where loads and shocks are most concentrated.

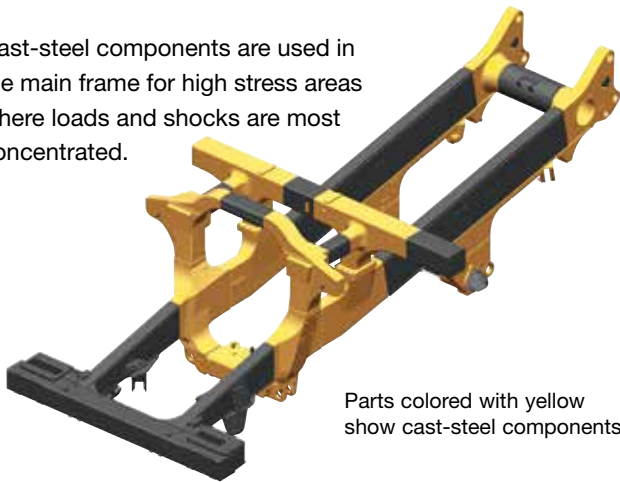

Parts colored with yellow show cast-steel components

Robust Dump Body Design

The body is built of 160 kg/mm² 227,520 PSI wear-resistant high-tensile steel with a Brinell hardness of 500. The V-shape and V-bottom design also increase structural strength. The side and bottom plates of the dump section are reinforced with ribs for added strength.

Reliable Hydraulic System

The oil cooler is installed underneath of the radiator, improving the reliability of the hydraulic system during sudden temperature rises. Further, in addition to the main filter, a 25 micron line filter is at the entrance to the transmission control valve. This system helps to prevent secondary faults.

Protection Functions Supported by Electronic Control

Item	Function
Downshift inhibitor	Even if the driver downshifts accidentally, a speed appropriate to the current gear is automatically set, preventing over-runs.
Over-run inhibitor	When descending grades, if the vehicle's speed surpasses the maximum for the current gear, the rear brakes automatically operate, preventing over-runs.
Reverse inhibitor	The vehicle is prevented from moving backward when operating the body.
Forward/Reverse shift inhibitor	This device makes it impossible to shift from forward to reverse when the vehicle's speed surpasses 4 km/hour.
Anti-hunting system	When running near a shift point, smooth automatic shifting takes place.
Neutral safety	The engine is prevented from starting when the shift lever is not in neutral.

Sealed DT Connectors

Main harnesses and controller connectors are equipped with sealed DT connectors providing high reliability, water resistance and dust resistance.



Lead-Free Radiator

In addition to compliance with emission regulations, a lead-free aluminum core is used for the radiator to meet global environmental requirements.

Flat Face-to-Face O-ring Seals

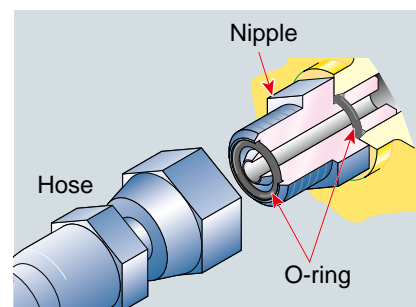

Flat face-to-face O-ring seals are used to securely seal all hydraulic hose connections and to prevent oil leakage.

Brake Cooling Oil Recovery Tank

To protect the environment, a tank is installed to recover brake cooling oil in the event of brake floating seal leakage.



EASY MAINTENANCE

Advanced Monitoring System

The Komatsu advanced monitoring system identifies maintenance items, reduces diagnostic times, indicates oil and filter replacement hours and displays abnormality codes. This monitor system helps to maximize machine production time.



Wet Multiple-Disc Brakes and Fully Hydraulic Controlled Braking Systems

Wet multiple-disc brakes and fully hydraulic controlled braking systems realize lower maintenance costs and higher reliability. Wet disc brakes are fully sealed to keep contaminants out, reducing wear and maintenance. Brakes require no adjustments for wear, meaning even lower maintenance. The parking brake is also an adjustment-free, wet multiple-disc system for high reliability and long life. Added reliability is designed into the braking system by the use of three independent hydraulic circuits providing hydraulic backup should one of the circuits fail. Fully hydraulic braking systems eliminate the air system so air bleeding is not required, and water condensation that can lead to contamination, corrosion and freezing is eliminated.

Centralized Arrangement of Filters

The filters are centralized so that they can be serviced easily.



Disc Wheels (Flange Type Rims)

Disc wheels (Flange type rims) provide easy removal/installation for the tires.

Extended Oil Change Intervals

In order to minimize operating costs, oil change intervals have been extended:

- Engine oil 500 hours
- Hydraulic oil 4000 hours

Electric Circuit Breaker

A circuit breaker is adopted in important electric circuits that should be restored in a short time when a problem occurs in the electrical system.



Centralized Greasing Points

Greasing points are centralized at three locations, it enables to approach from ground level.



KOMTRAX Plus

KOMTRAX Plus controller monitors the health conditions of major components, enables remote analysis of the machine and its operation. This process is supported by the Komatsu distributors, factory and design team. This contributes to reduced repair costs and to maintaining maximum availability.

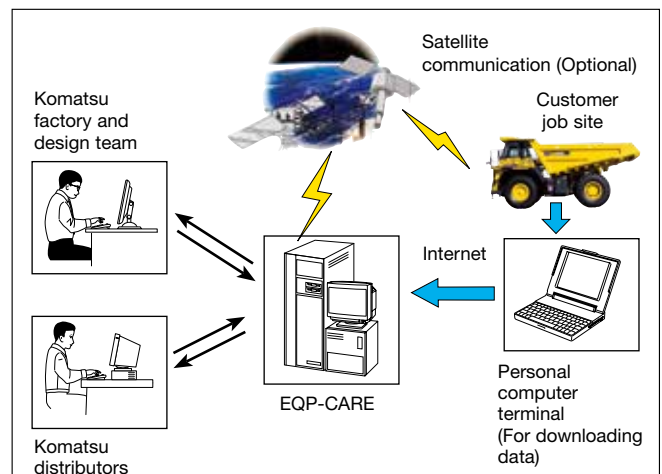

KOMATSU TOTAL SUPPORT



Komatsu Total Support

To keep your machine available and minimize operation cost when you need it, Komatsu Distributor is ready to provide variety of support before and after procuring the machine.

Fleet recommendation

Komatsu Distributor can study the customer's job site and provide the most optimum fleet recommendation with detailed information to meet all of your application needs when you are considering to buy new machines or replace the existing ones from Komatsu.



Product support

Komatsu Distributor gives the proactive support and secures the quality of the machinery that will be delivered.

Parts availability

Komatsu Distributor is available for emergency inquiry by the customers for genuine, quality guaranteed Komatsu parts.

Technical support

Komatsu product support service (Technical support) are designed to help customer. Komatsu Distributor offers a variety of effective services how much Komatsu is dedicated to the maintenance and support of Komatsu machine.

- Preventive Maintenance (PM) clinic
- Oil & Wear analysis program

Repair & maintenance service

Komatsu Distributor offers quality repair and maintenance service to the customer, utilizing and promoting Komatsu developed programs.

Komatsu Reman (Remanufactured) components

Komatsu Reman products are the result of the implementation of the Komatsu global policy which establishes and agrees to reduce the owning, operating and total Life Cycle Costs (LCC) to Komatsu's customer through high quality, prompt delivery and competitively priced in own remanufactured products (QDC).



SPECIFICATIONS



ENGINE

Model	Komatsu SAA6D170E-5
Type	Water-cooled, 4-cycle
Aspiration	Turbo-charged, air-to-air after-cooled
Number of cylinders	6
Bore x stroke	170 mm x 170 mm
Piston displacement	23.15 L
Horsepower	
SAE J1995	Gross 551 kW 739 HP
ISO 9249 / SAE J1349	Net 533 kW 715 HP
Rated rpm	2000 min ⁻¹
Fan drive type	Mechanical
Maximum torque	3320 N-m 339 kg-m
Fuel system	Direct injection
Governor	Electronic control
Lubrication system	
Method	Gear pump, force-lubrication
Filter	Full-flow type
Air cleaner	Dry type with double elements and precleaner (cyclonpack type), plus dust indicator



TRANSMISSION

Torque converter	3-elements, 1-stage, 2-phase
Transmission	Full-automatic, planetary type
Speed range	7 speeds forward and 1 reverse
Lockup clutch	Wet, multiple-disc clutch
Forward	Torque converter drive in 1st gear, direct drive in 1st lockup and all higher gears
Reverse	Torque converter drive
Shift control	Electronic shift control with automatic clutch modulation in all gear
Maximum travel speed	70.0 km/h



AXLES

Rear axles	Full-floating
Final drive type	Planetary gear
Ratios:	
Differential	3.538
Planetary	4.737



SUSPENSION SYSTEM

Independent, hydropneumatic suspension cylinder with fixed throttle to dampen vibration.	
Effective cylinder stroke (front suspension)	303 mm
Rear axle oscillation:	
Oil stopper	6.8°
Mechanical stopper	7.7°



STEERING SYSTEM

Type	Fully hydraulic power steering with two double-acting cylinders
Supplementary steering	Manual control (meets ISO 5010 and SAE J1511)
Minimum turning radius	8.5 m
Maximum steering angle	39°



CAB

Dimensions comply with ISO 3471 ROPS (Roll-Over Protective Structure) standard, and ISO 3449 FOPS standard.



MAIN FRAME

Type	Box-sectioned structure
------	-------------------------



BRAKES

Brakes meet ISO 3450 standard.	
Service brakes:	
Front	Fully hydraulic control, caliper disc type
Rear	Fully hydraulic control, oil-cooled multiple-disc type
Parking brake	Spring applied, multiple-disc type
Retarder	Oil-cooled, multiple-disc rear brakes act as retarder.
Secondary brake	Manual pedal operation.
When hydraulic pressure drops below the rated level, parking brake is automatically actuated.	
Brake surface	
Front	1936 cm ²
Rear	64230 cm ²



BODY

Capacity:	
Struck	29.0 m ³
Heaped (2:1, SAE)	40.0 m ³
Payload	63.0 metric tons
Material	160 kg/mm ² high-tensile-strength steel
Structure V-shape body with V-bottom	
Material thickness:	
Bottom	25 mm
Front	16 mm
Sides	14 mm
Target area (inside length x width) 6600 mm x 3870 mm	
Dumping angle	48°
Height at full dump	8800 mm
Heating	Exhaust heating



HYDRAULIC SYSTEM

Hoist cylinder	Twin, 2-stage telescopic type
Relief pressure	20.6 MPa 210 kg/cm ²
Hoist time	11.5 sec



WEIGHT (APPROXIMATE)

Empty weight	46200 kg
Max. gross vehicle weight	110180 kg
Not to exceed max. gross vehicle weight, including options, fuel and payload.	
Weight distribution:	
Empty: Front axle	47%
Rear axle	53%
Loaded: Front axle	32%
Rear axle	68%



TIRES

Standard tire	24.00 R35
---------------	-----------



SERVICE REFILL CAPACITIES

Fuel tank	780 L
Engine oil	80 L
Torque converter, transmission and retarder cooling	215 L
Differential	95 L
Final drives (total)	42 L
Hydraulic system	122 L
Suspension (total)	55.6 L



DIMENSIONS

Unit: mm

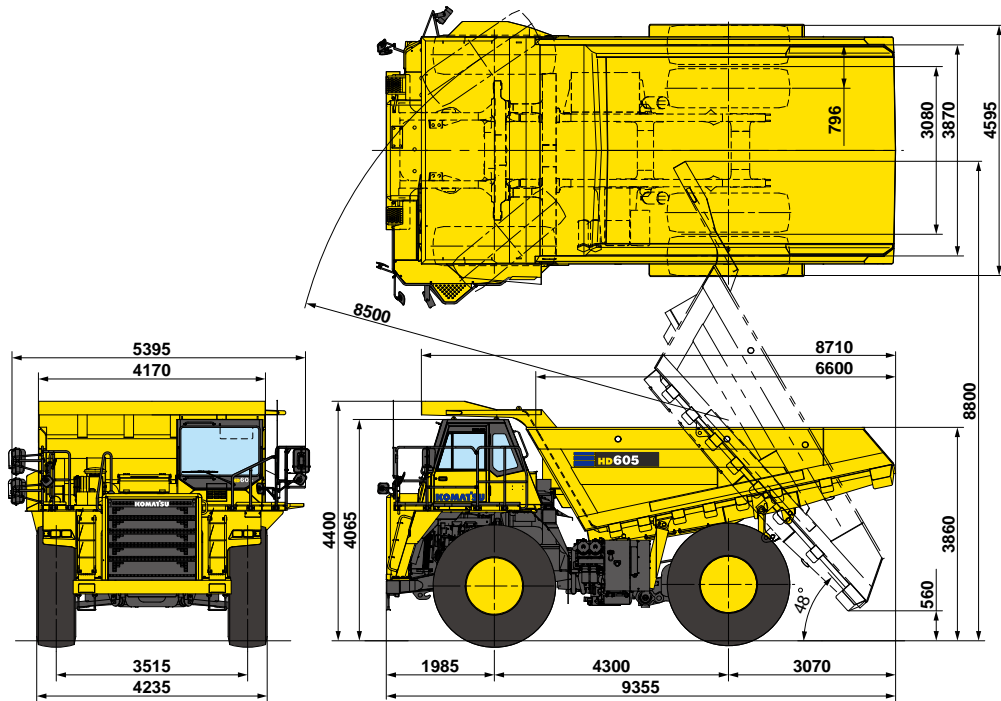

TRAVEL PERFORMANCE

To determine travel performance: Read from gross weight down to the percent of total resistance. From this weight-resistance point, read horizontally to the curve with the highest obtainable speed range, then down to maximum speed. Usable rimpull depends upon traction available and weight on drive wheels.

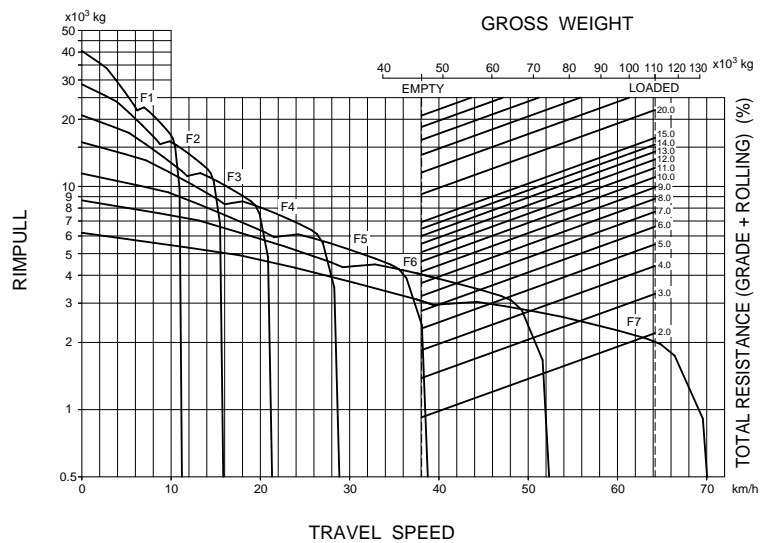

BRAKE PERFORMANCE

To determine brake performance: These curves are provided to establish the maximum speed and gearshift position for safer descents on roads with a given distance. Read from gross weight down to the percent of total resistance. From this weight-resistance point, read horizontally to the curve with the highest obtainable speed range, then down to maximum descent speed the brakes can safely handle without exceeding cooling capacity.

Grade distance: Continuous Descent

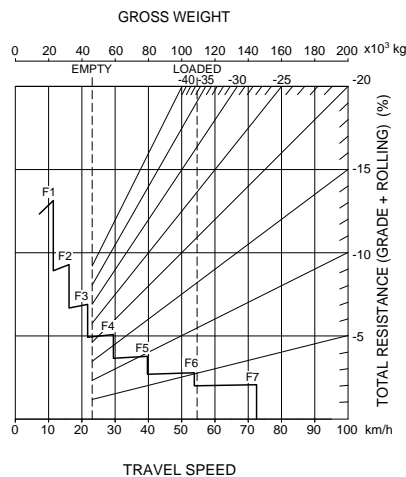

Grade distance: 450 m

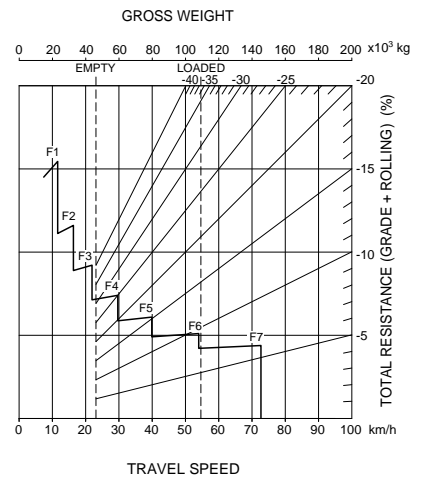

**STANDARD EQUIPMENT****ENGINE:**

- Automatic Idling Setting System
- Alternator, 90A/24V
- Batteries, 2 x 12V/200Ah
- Engine, Komatsu SAA6D170E-5
- Mode selection system
- Starting motor, 2 x 7.5 kW

CAB:

- Ashtray
- Cigarette lighter
- Cup holder
- Electronic dump control system
- Electronic maintenance display/monitoring system
- Laminated glass, front
- Operator seat, reclining, suspension type
- Passenger seat with retractable seat belt
- Power window (LH)
- ROPS cab with FOPS, sound suppression type
- Seat belt for operator seat, 78 mm width, retractable, 2 point
- Space for lunch box
- Steering wheel, tilt and telescopic
- Sunvisor

- Two doors, left and right
- Windshield washer and wiper (with intermittent feature)

LIGHTING SYSTEM:

- Back-up light
- Hazard lights
- Headlights with dimmer switch
- Indicator, stop and tail lights

GUARD AND COVERS:

- Drive shaft guard (front and rear)
- Exhaust thermal guard
- Fire protective covers

SAFETY EQUIPMENT:

- Alarm, backup
- ARSC
- Coolant temperature alarm and light
- Front brake cut-off system
- Hand rails for platform
- Horn, electric
- Ladders, left and right hand sides
- Overrun warning system
- Rearview mirrors and under view mirrors
- Supplementary steering

OTHER:

- Centralized greasing
- Electric circuit breaker, 24V
- Mud guards

BODY:

- Body exhaust heating
- Cab guard, left side
- Spill guard, 150mm

TIRES:

- 24.00 R35

**OPTIONAL EQUIPMENT****CAB:**

- Air conditioner
- Operator seat, air suspension type
- Power window (RH)
- Radio, AM/FM with cassette
- Seat belt for operator seat, 50 mm width, retractable, 3-point
- Sunvisor, additional

BODY:

- Platform guard, right hand side
- Spill guard, 300 mm
- Without body heating (with muffler)

LIGHTING SYSTEM:

- Back work lights, left and right sides
- Fog lights
- Yellow beacon

SAFETY:

- ABS
- ASR
- Automatic supplementary steering
- Rear view camera and monitor
- Stairway

ARRANGEMENT:

- Batteries for cold area arrangement
- Cold area arrangement
- Sandy and dusty area arrangement

OTHER:

- Auto-greasing system
- Engine coolant heater
- Engine oil pan heater
- Engine side cover
- Engine underguard
- Fire extinguisher
- Fuel quick charge
- KOMTRAX Plus

- KOMTRAX Plus with satellite communication kit
- Muffler (no body heating type)
- PLM
- PLM with overload limiter
- Radiator shutter, canvas type
- Spare parts for first service
- Speed limiter
- Three-mode hydropneumatic suspension
- Tool kit
- Transmission underguard
- Vandalism protection



Rear view camera and monitor



Stairway

Standard equipment may vary for each country, and this specification sheet may contain attachments and optional equipment that are not available in your area. Please consult your Komatsu distributor for detailed information.

